



HEMAN

Innovando para Usted...®

CONTACTO HEMAN

Adolfo Duclos Salinas Mz. 170 Lt. 14
Santa Martha Acatitla Norte
Iztapalapa CDMX

- 5557339915
- 5557347271
- 5557336711

ventas@heman.com.mx

www.heman.com.mx

ENCUENTRANOS EN:



Escanea



Ficha técnica

LAVA BUCHES Y PATAS

02

LAVA BUCHES Y PATAS

Ideal para la limpieza de vísceras, paras y buches. Construido en acero inoxidable grado alimenticio con un sistema de tómbola repujada, que garantiza mayor limpieza.

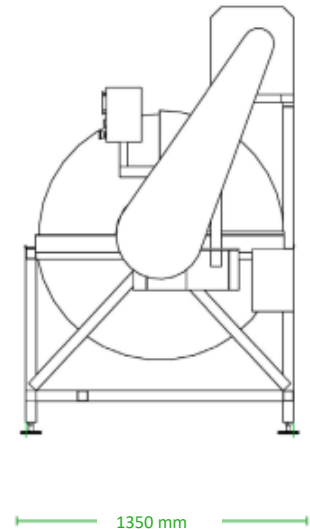
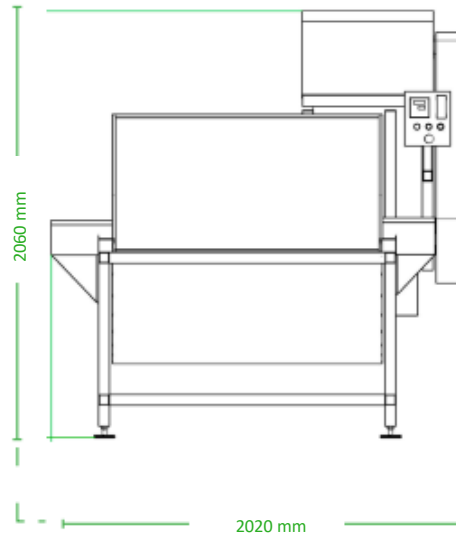





VIDEO

Especificaciones técnicas

MOTOR	5 hp
CAMPACIDAD DE TRABAJO	400 Kg
CONTROL	Análogo
TIPO DE CONEXIÓN	220 v 3 fases 4 polos
VELOCIDAD	Variable
TRANSMISIÓN	Por cadena

Ventajas

-  Contruida en acero inoxidable tipo 304
-  Control de arranque y paro
-  Con temporizador
-  Control de giro

